

MoJet Tunnel Ventilation – Full-Scale Testing and CFD Analysis

*F Tarada, K Else, A Domoney
Mosen Ltd*

*P Hendrick, A Tarhach
Université Libre de Bruxelles*

*A Mugisha, A Kabuya
Bruxelles Mobilité, Service Public Régional de Bruxelles*

A series of experimental measurements and 3D CFD calculations were undertaken to compare the air velocities, effective thrust and power consumption of two types of ventilation systems at the Montgomery Tunnel in Brussels: conventional jefans and MoJets. The MoJet solution was shown by the CFD analysis to provide approximately 100% more thrust compared to conventional jefans, with lower power consumption per fan. These results were confirmed by the experimental measurements undertaken in an empty tunnel. The MoJet therefore offers a cost-effective and environmentally friendly option for new and existing longitudinal tunnel ventilation systems.

1 INTRODUCTION

A number of alternative technologies have previously been proposed for the improvement of jefan in-tunnel thrust, including deflection vanes (with or without a clearance between the jefan outlet and the vanes, Ref. (1)), the Banana Jet (slanted silencers, Ref. (2)), constructing tunnel niches, and installing jefans at portals blowing towards the tunnels.

MoJets are jefans with shaped silencers which direct the discharged flow away from adjacent tunnel surfaces (Ref. (3)). This reduces the Coanda effect, thereby increasing the aerodynamic thrust delivered to the tunnel air. A previous paper using 3D CFD analysis (Ref. (4)) suggested that MoJets can achieve a significant increase in in-tunnel thrust while reducing the motor power consumption. The design of the MoJet is compact, with no slanted silencers, and is therefore suitable as a like-for-like replacement for jefans.

In order to compare the performance of the MoJet with conventional jefans, an experimental campaign was undertaken at the Montgomery Tunnel in Brussels. The design of the experiments was arranged by means of a prior 3D CFD study.

The research work reported here was sponsored by Service Public Régional de Bruxelles, which is the public-sector owner of all highway tunnels in Brussels. Aerodynamic measurements were undertaken by Université Libre de Bruxelles (ULB), and CFD computations were carried out by Mosen Ltd.

2 MOJET DESIGN

The MoJet is a modified form of jefan which uses circular silencer inlets/outlets tilted at an angle about the fan centreline (Figure 1). The circular inlets/outlets have a larger diameter than for an equivalent conventional jefan, and thus a greater area. The tilted

silencer outlet directs the discharged air away from the nearby tunnel surfaces, thus reducing the Coanda effect and enhancing the in-tunnel thrust (Ref. (4)). If MoJet inlet silencers are installed on a jetfan, the larger inlet area (22% area increase for a 25° tilt) facing away from the tunnel soffit ensures that the inlet pressure drop to the fan is reduced compared to a conventional jetfan. This increases the mass flow through the fan, while reducing the power consumption (Ref. (4)).

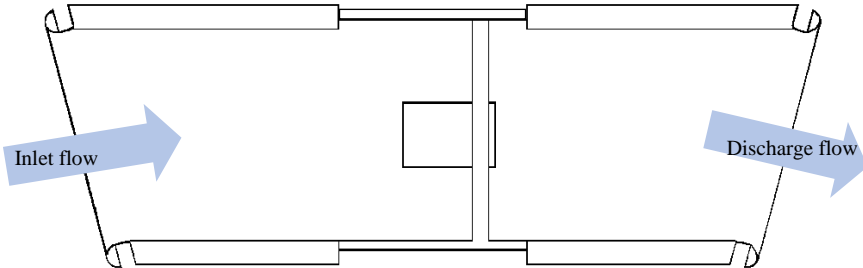

Figure 1: Reversible MoJet design, with MoJet silencers on both sides of fan (Ref. (3))

3 TUNNEL VENTILATION ARRANGEMENTS

The Montgomery Tunnel is 528 m long with two tubes. Each tube carries two traffic lanes and is ventilated by 10 conventional corner-mounted jefans. The jefans are located at separation distances of approximately 48 m from each other and from the portals. During the experimental tests, three of the existing jefans in the northbound tunnel were replaced by

- (a) new conventional jefans of 630 mm internal diameter (Figure 2 and Figure 4);
- (b) the new conventional jefans referred to in (a) above, but with the discharge silencers replaced by MoJet nozzles (Figure 3 and Figure 4). The flanges connecting the MoJet silencers to the fan casing had an angular hole pitch of 30°. The MoJet silencers were arranged to discharge the flow towards the 8 o'clock position, i.e. at a 60° angle from the vertical axis, to direct the flow away from the wall and the soffit (Figure 5).

The locations of the test jefans along the tunnel are indicated in Figure 6. A typical tunnel cross-section at a jefan location is shown in Figure 10.

The experimental test described in this paper was undertaken using the three conventional jefans described in (a) above, and a separate test with the three MoJets described in (b) above.

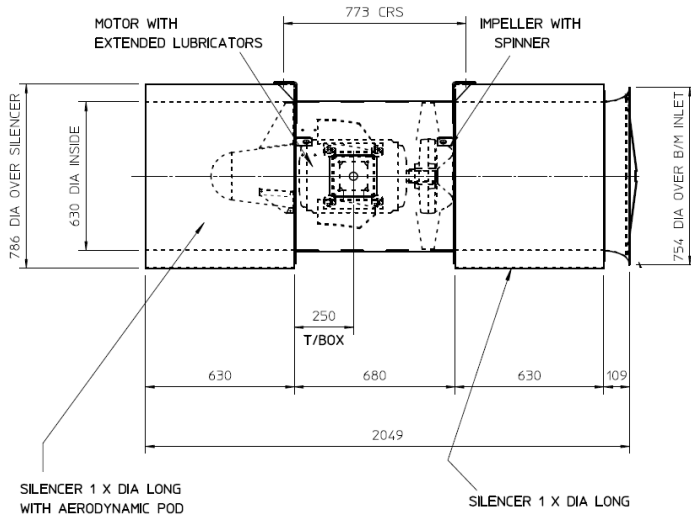

Figure 2: Conventional jetfan design (dimensions in mm)

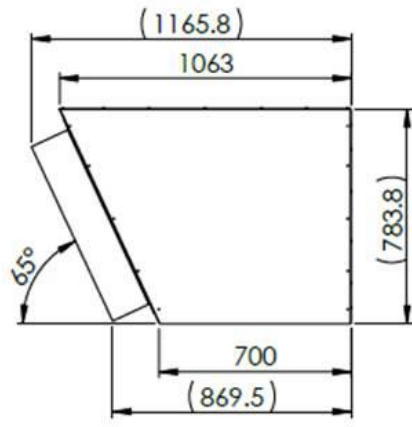

Figure 3: Outline of MoJet discharge silencer design (dimensions in mm)

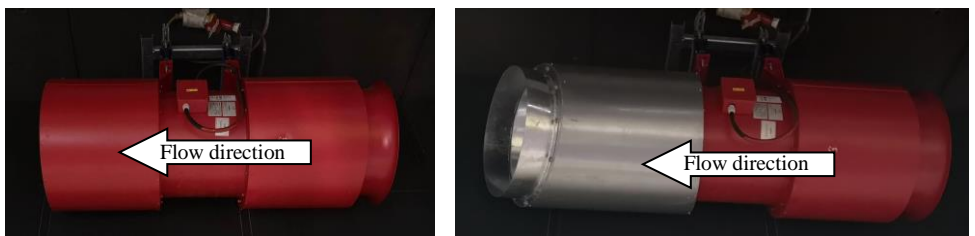

Figure 4: Conventional jetfan (left) and MoJet (right) installed in tunnel

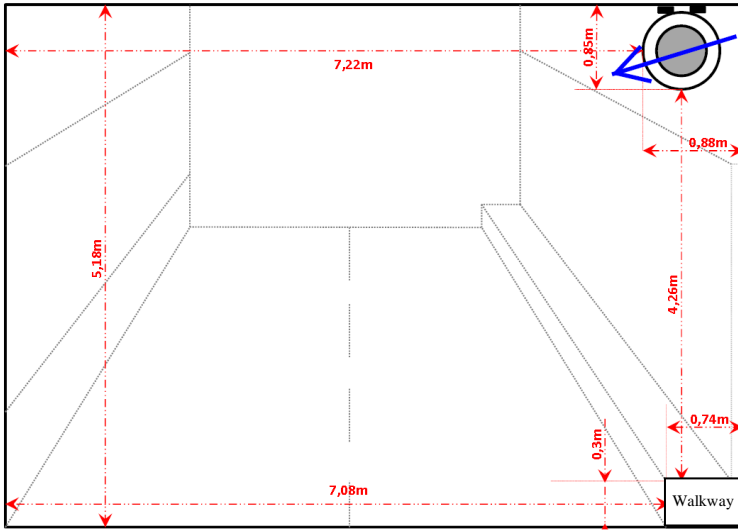

Figure 5: Tunnel cross-section and MoJet discharge direction (indicated via blue arrow)

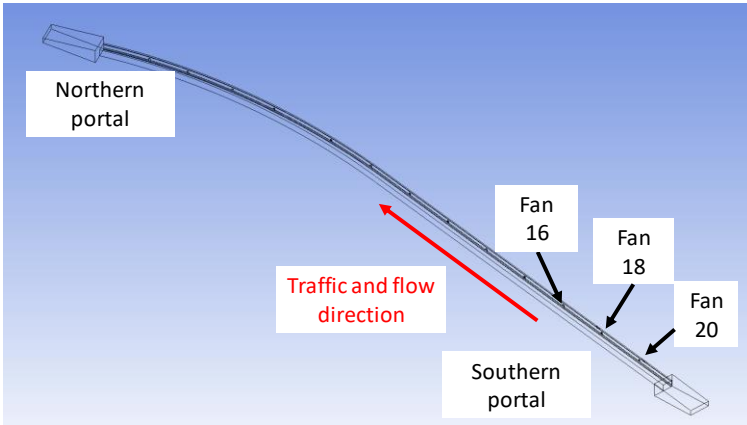

Figure 6: Location of test jettans within the Montgomery Tunnel

4 3D CFD COMPUTATIONS

At the outset of this research project, steady-state 3D CFD predictions of the tunnel and fan flow-fields were undertaken for both the conventional jetfan and the MoJet cases using ANSYS CFX. The CFD calculations included the full geometrical details of the internal fan geometry of each of the three conventional jettans / MoJets, including the blades, motor, centre-body and supporting struts. The shear stress transport $k-\omega$ turbulence model was used to capture aerodynamic separation and swirl effects as accurately as possible. The total energy equation with the viscous work terms was solved in addition to the momentum and turbulence equations. A fan rotational speed of 2900 rpm was set for both the conventional and the MoJet cases. No external wind was assumed in the CFD calculations.

The first set of CFD calculations were undertaken for a conventional jetfan and a MoJet simulating bench thrust conditions, in order to compare these results with measurements

undertaken in accordance with ISO BS EN 13350:2015 “Performance Testing of Jet Fans”. These calculations used 23 million cells for the conventional jetfan and 29 million cells for the MoJet. For a 21° blade pitch angle, our CFD calculations indicated a mass-average discharge airflow velocity of 27.5 m/s for the conventional jetfan (Figure 7) and 30.8 m/s for the MoJet, which compares reasonably well with the 30.5 m/s which can be interpreted from the conventional jetfan bench thrust test. The MoJet achieved a deflection angle of 11° from the horizontal axis (Figure 9).

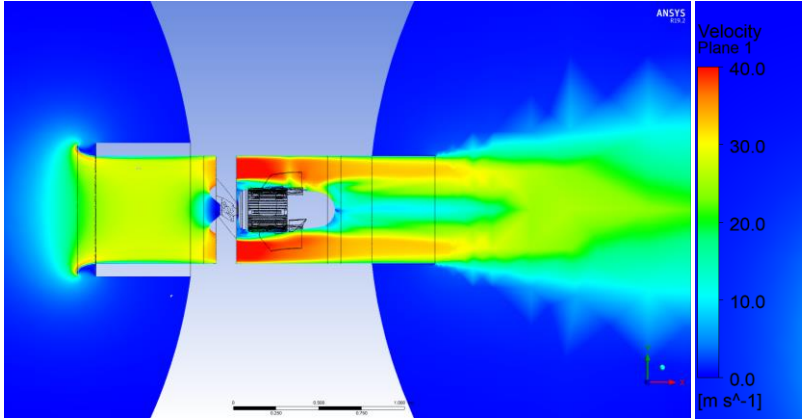

Figure 7: CFD-computed velocity field for conventional jetfan under bench thrust conditions

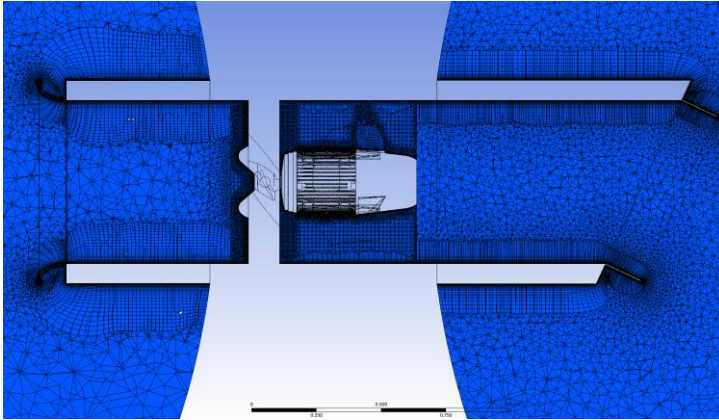

Figure 8: 630 mm ID jetfan with MoJet discharge silencer (with 3D CFD mesh)

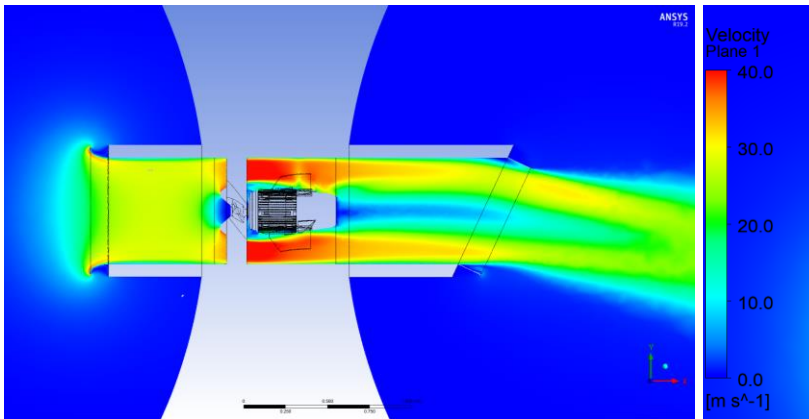

Figure 9: CFD-computed velocity field for MoJet under bench thrust conditions

The second set of CFD computations involved modelling the conventional jetfans and MoJets within the Montgomery Tunnel (Figure 10). Each of these computations required approximately 50 million cells.

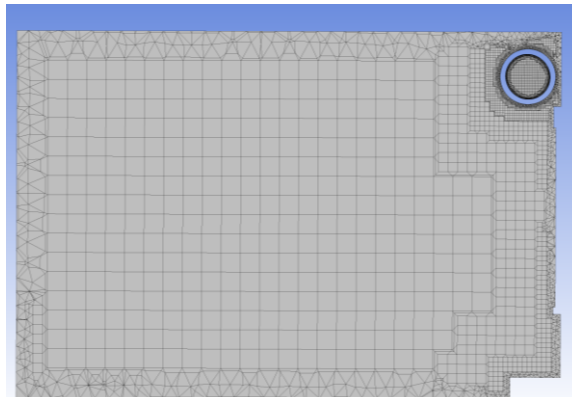

Figure 10: Tunnel cross-section at a jetfan location (with 3D CFD meshing)

Figure 11 shows the CFD-computed streamlines originating from the conventional jetfans and MoJets. The (red) streamlines from the upstream conventional jetfans stick closely to the tunnel corner due to the Coanda effect, and are ingested into the downstream jetfans. The friction between the jet and the tunnel walls, as well as the ingestion of high-velocity airflow into the downstream jetfan intake, both cause a reduction in the effective thrust. The (blue) streamlines from the MoJet are mostly directed towards the tunnel centreline, and thus overcome the Coanda effect. The contours of wall shear stress indicate much higher levels in the vicinity of the conventional jetfans, compared to the MoJet (Figure 12).

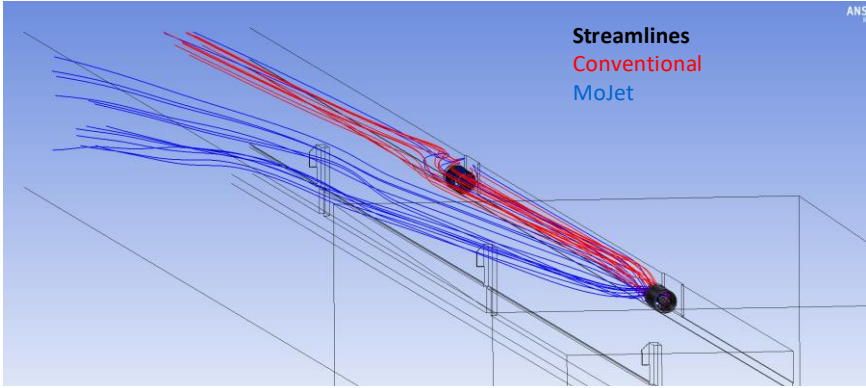

Figure 11: CFD-computed streamlines originating from conventional jetfans and MoJets

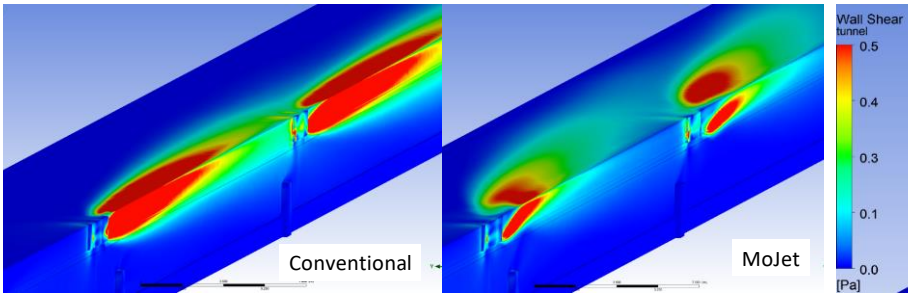

Figure 12: CFD-computed wall shear stress along the tunnel surfaces [Pa]

In order to estimate the jetfan installation factors for the conventional jetfan and MoJet cases, the 3D CFD models were matched with equivalent 1D aerodynamic models using IDA RTV (<https://www.equa.se/en/tunnel/ida-rtv/overview>), as described below.

The value of in-tunnel thrust T is calculated in IDA RTV as

$$T = \eta_i \rho A_A v_A (v_A - v_T) \quad (\text{Equation 1})$$

where η_i is the jetfan installation factor, A_A is the cross sectional area of the fan, v_A the jet average velocity and v_T the velocity in the tunnel beyond the direct influence of the jetfan intake and discharge.

In order to match the tunnel air velocities calculated by the 3D CFD results within IDA RTV, the installation factor had to be set at 0.25 for the conventional jetfans, and 0.53 for the MoJet. The low installation factor for corner-mounted conventional jetfans is consistent with the small tunnel velocities measured at the Heathrow Main Landside Tunnels (Ref. (5)).

5 EXPERIMENTAL MEASUREMENTS

Two sets of aerodynamic measurements were undertaken:

- (1) Steady-state measurements with conventional jetfans 16, 18 and 20 switched on for 10 minutes (see Figure 6).

- (2) Steady-state measurements with MoJets 16, 18 and 20 switched on for 10 minutes (see Figure 6).

During the tests, airflow measurements were undertaken via an ultrasonic probe at the middle of the southbound tunnel chainage (Figure 14) and at 16 m from the exit portal of the northbound tunnel. The latter location was selected as it was remote from the operating jetfans, and the velocity profile was expected to be reasonably uniform there.

The aerodynamic measurements near the north portal comprised:

- (1) A 5×5 grid of Kiel probes, supported by vertical struts (Figure 14);
- (2) Three pitot/static probes arranged at different heights on the central strut. The mid-height static pressure probe was selected as the reference pressure for all measurements.

The manufacturer’s data sheet for the Kiel probes indicated that they were insensitive to yaw angles of up to 60°. The Kiel probes were independently calibrated at ULB’s wind tunnel against a previously calibrated hot-wire anemometer.

The 25 Kiel probes were geometrically positioned following the log-Chebyshev rule as described in ISO 5802:2001 (“Industrial fans - Performance testing in situ”), see Figure 14. Consequently, the mean flow velocity near the north portal was obtained by a time and area-average of the 25 velocity readings from the Kiel probes.

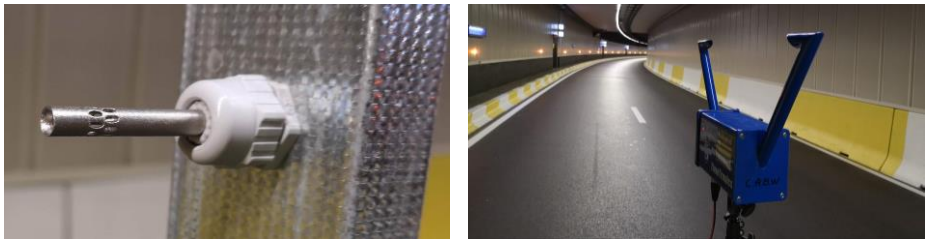

Figure 13: Left: Kiel probe installed in the measurement grid at the north portal, right: ultrasonic probe used to monitor wind-induced velocities

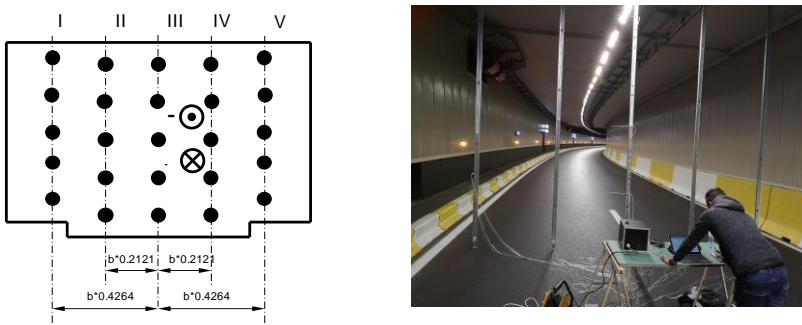

Figure 14: Airflow measurement locations (left: probe positions according to ISO 5802:2001, right: airflow measurement grid on site)

The effect of external wind was accounted for by measuring the average air velocity near the northern portal before and after the measurements were undertaken. The wind-induced air velocity was converted into an equivalent wind thrust within the tunnel. This

wind thrust was subtracted from the total thrust to estimate the thrust due to the jetfans. The ultrasonic probe at the middle of the southbound tunnel chainage was used to monitor any changes in wind-induced velocity during the tests.

The in-tunnel aerodynamic thrust due to the jetfans was calculated from the measured air velocities using

$$T = (1 + \zeta_e + \lambda \frac{L}{D}) \frac{\rho A (v_T^2 - v_w^2)}{2} \quad \text{Equation (2)}$$

where:

- A : tunnel cross-sectional area (= 39.6 m²)
- ρ : density of air (= 1.19 kg/m³)
- λ : wall-friction coefficient of the tunnel (\approx 0.025)
- L : length of tunnel (= 528 m)
- D : hydraulic diameter of tunnel section (= 6.14 m)
- ζ_e : loss coefficient at entry portal (assumed to be 0.6)
- v_w : wind-induced velocity, averaged in time and over the tunnel cross-sectional area (m/s)

For comparative purposes, the thrust values were referred to normal temperature and pressure conditions. The measured results are summarised in Table 1.

	Average velocity at north portal (v_T) (m/s)	Average wind-induced velocity (v_w) (m/s)
Conventional jetfan	3.650	1.495
MoJet	4.914	1.386

Table 1: Time-averaged aerodynamic measurements results

The measurements indicated that the ratio of MoJet to conventional jetfan in-tunnel thrust was 2.0, with an error and uncertainty band of $\pm 10\%$.

The current and voltage readings for all three phases supplying the three jetfan motors were measured during the two tests. The results indicate that the three MoJets drew 1% less power compared to the conventional jetfans. Previous studies indicate that had MoJet inlet silencers been used as well as outlet silencers, a significantly lower power consumption would have been achieved (Ref. (4)).

6 DISCUSSION

Figure 15 shows the computed velocity fields at the northern portal. The MoJet case exhibited an area-average flow velocity of 2.28 m/s, which is 44% higher than the conventional jetfan case of 1.59 m/s. This is equivalent to a 106% increase in thrust for the MoJet compared to the conventional jetfan.

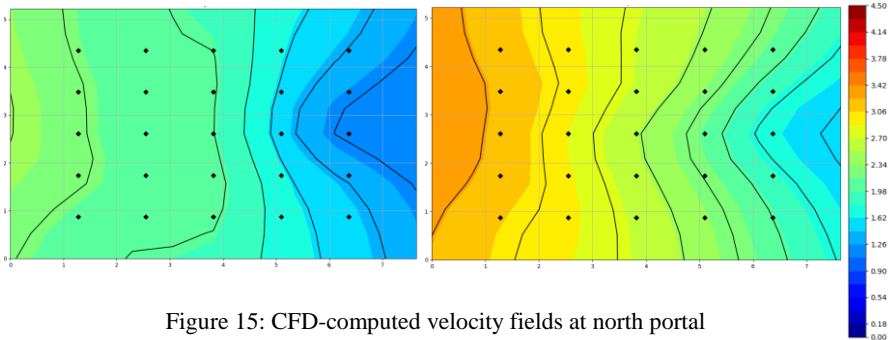

Figure 15: CFD-computed velocity fields at north portal (left: conventional jetfan, right: MoJet, values in m/s)

The measured velocity increments above the local wind-induced velocity are presented in Figure 16. Certain features, including the biasing of the flow towards the left-hand (eastern) wall for the MoJet, appear in both the CFD and experimental results. The conventional jetfan CFD results appear to lower on the right-hand (western) wall compared to the measurements. The MoJet velocity measurements appear to be higher on the corner with between the left-hand (eastern) wall and the floor than indicated by the CFD results. Although the CFD estimate of the in-tunnel thrust ratio between the MoJet and the conventional jetfans is consistent with the experimental measurements, the details of the calculated velocity flow field at the exit (north) portal could be improved, most likely by adopting a finer mesh.

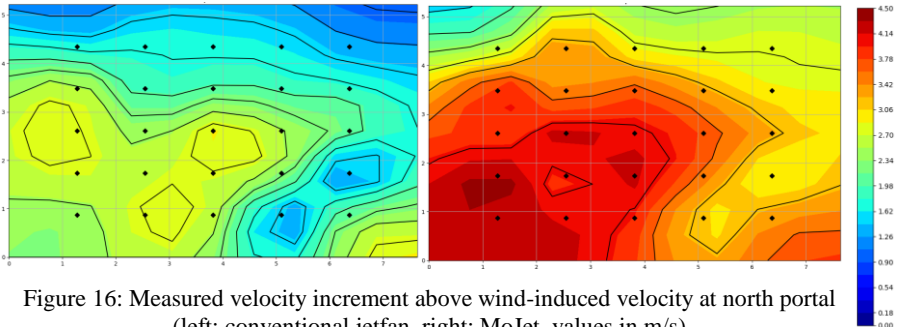

Figure 16: Measured velocity increment above wind-induced velocity at north portal (left: conventional jetfan, right: MoJet, values in m/s)

7 CONCLUSIONS

The original jetfan arrangement in the Montgomery Tunnel, with conventional jetfans that are mounted in corners and spaced closely together, leads to a high degree of friction between the discharged jets and the tunnel surfaces, as well as causing the ingestion of upstream jets by downstream jetfans. These two effects lead to low values of in-tunnel aerodynamic thrust and installation factor. The MoJet solution directs the flow away from the tunnel surfaces and from downstream jetfans, hence improving the aerodynamic thrust and installation factor.

Our experiments confirm the CFD-calculated enhancement of in-tunnel thrust of the three MoJets by approximately 100% compared to three conventional jetfans, within a $\pm 10\%$ measurement uncertainty band. An even higher percentage increase in thrust would be expected if all ten jetfans in the northbound tunnel had been used, rather than just three. This is because the first conventional jetfan (near the southern portal) is not compromised by a high ingested velocity from an upstream jetfan, and therefore makes a

disproportionately high positive contribution to the overall thrust when only three jefans are operated.

Our measurements indicated a slightly lower power consumption for the MoJet compared to conventional jefans. The combination of greater in-tunnel thrust and reduced power consumption suggests that the MoJet is a cost-effective and environmentally friendly method of longitudinal tunnel ventilation.

Our next research target is to investigate the enhancement of in-tunnel thrust using reversible MoJets, using both 3D CFD calculations and full-scale measurements.

8 REFERENCES

Ref. (1): “Investigation of the Wall-friction, Pressure Distribution and the Effectiveness of Big Jefans with Deflection Blades in the Fodnes Tunnel in Norway”, 9th International Symposium on Aerodynamics and Ventilation of Vehicle Tunnels, G. Lotsberg, Aosta Valley, Italy, 1997.

Ref. (2): Effective Thrust Transformation inside Tunnels with Jet Fans (Banana Jet), 4th International Conference ‘Tunnel Safety and Ventilation’, K.C. Witt and J. Schütze, Graz, 2008.

Ref. (3): “Optimised Tunnel Ventilation Device”, International PCT Patent Application Number PCT/GB2018/000029, F. Tarada, 2018.

Ref. (4): “Technologies for the Improvement of Jetfan Installation Factors”, by F. Tarada and K. Else, 9th International Conference ‘Tunnel Safety and Ventilation’ 2018, Graz.

Ref. (5): “Heathrow Airport Limited, Main Landside Road Tunnel, Tunnel Ventilation System Study”, Jacobs, Report No J24172A5/510/01.1, April 2006.