

# DEFLECTORS FOR TUNNEL JET FANS

Fathi Tarada  
Mosen Ltd

## ABSTRACT

Deflection vanes are sometimes used to turn the discharged flow away from tunnel surfaces, in order to counteract the Coanda effect and enhance the in-tunnel thrust. The aerodynamic effectiveness of such deflectors has been confirmed by a range of researchers. This paper addresses the effect of deflectors on the in-tunnel thrust, as well as their effect on reducing jet fan bench thrust, increasing noise production and power consumption, the risk of structural failure due to fatigue, and extending the jet throw causing the buffeting of vehicles and pedestrians during use. It is concluded that the optimisation of deflector location and vane deflection angle can assist in mitigating, but not eliminating, some of the negative aspects of deflector use. Modern alternatives to deflectors including the MoJet have been developed, and have demonstrated superior performance.

*Keywords: Deflectors, jet fan, thrust, Coanda effect, noise, fatigue, installation factor, power consumption*

## 1. INTRODUCTION

Jet fans serve to ventilate tunnels by discharging a high-speed jet, typically between 30 to 40 m/s velocity, and impart some of the jet's longitudinal momentum into the tunnel air. Depending on the location of the jet fan, part of that momentum (typically between 20% under arched soffits to 50% in rectangular corners) is dissipated due to friction between the jet and the bounding tunnel surfaces (soffit and walls). If the jet can be turned away from the tunnel surfaces to overcome the Coanda effect, the friction between the jet and the tunnel surfaces can be reduced, leading to an improvement in the in-tunnel thrust generated by the jet fans.

One of the means by which such turning of the jet is obtained is through the installation of deflectors. Such deflectors comprise an array of turning vanes, installed downstream of the discharge silencers. For reversible jet fans, deflectors are required at both ends of a jet fan (Figure 1).

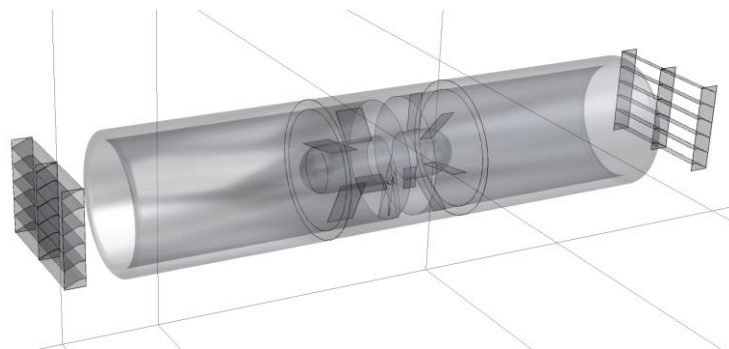

Figure 1: Reversible jet fan with deflectors

The experimental measurements of Lotsberg (1997) and Beyer et al (2016) have confirmed that deflectors can be effective in turning the discharge flow and in increasing the tunnel air velocity for a given installation of jet fans. For example, Beyer et al (2016) reported an improvement in jet fan installation factor (indicating the ratio of in-tunnel to bench thrust) by up to 20%, with a vane deflection angle of 19°. However, no comprehensive study has yet been reported on the effect of deflectors on jet fan thrust, noise and durability. This paper addresses some of these issues.

## 2. EFFECT OF DEFLECTORS ON JET FAN BENCH THRUST

In order to quantify the influence of deflectors on the bench thrust and sound power levels generated by jet fans, a series of experimental measurements were conducted on a 710 mm internal diameter jet fan driven by a 2-pole motor running at 2970 rpm, with 1-D silencers installed on both sides of the jet fan.

The first set of measurements involved testing the influence of deflector positioning, using a rectangular deflector with curved vanes with a deflection angle of  $26^\circ$ , as depicted in Figure 2. The fan blade pitch angle was set to  $32^\circ$  for this set of measurements.

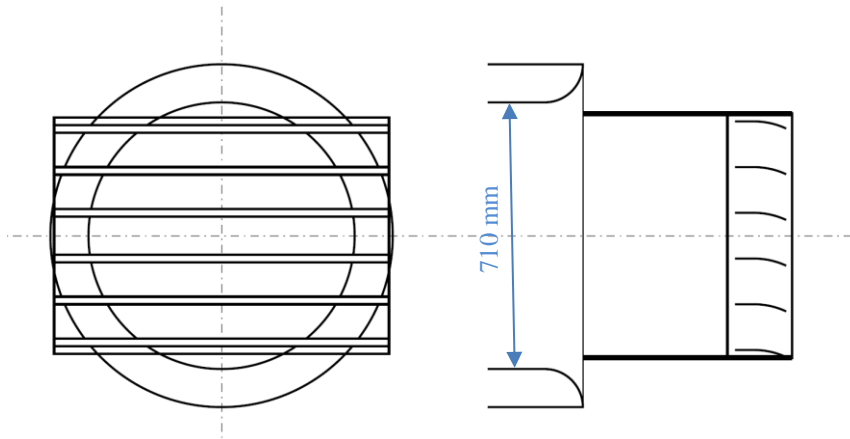

Figure 2: Rectangular Deflector used in Measurements

The jet fan was mounted on a thrust bench and measurements of longitudinal thrust were undertaken in accordance with ISO 13350:2015 “Fans - Performance testing of jet fans”. The baseline thrust, corresponding to the forward flow direction with no deflectors, was measured as 598.5 N. All thrust measurements were subject to an overall uncertainty (including systemic and random errors) of  $\pm 5\%$ . The results of this set of measurements are summarised in Figure 3.

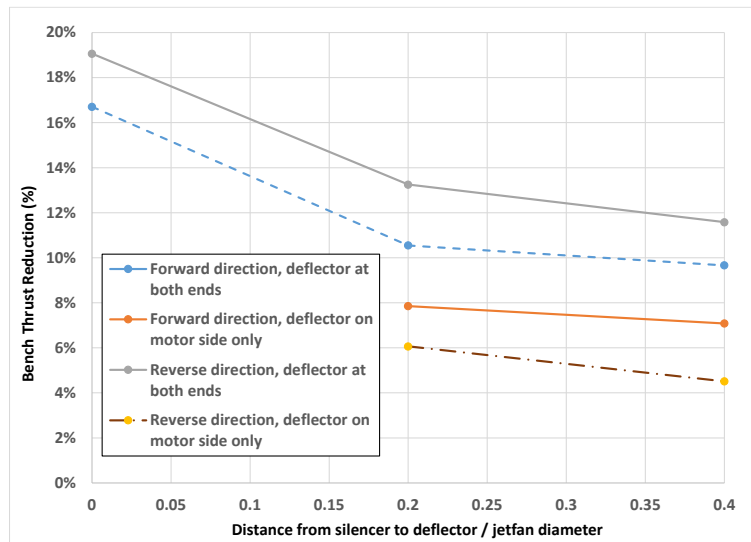

Figure 3: Thrust Reduction as a Function of Deflector Location

Figure 3 indicates that coupling the deflectors directly to the silencer ends is not recommended, since that can lead to thrust losses in excess of 20%. Increasing the distance between the silencers and the deflectors ameliorates the thrust reduction, but a thrust reduction of around 10% was still observed with deflectors installed at  $0.4D$  from both ends of the jet fan, for a forward flow direction (where  $D$  is the internal jet fan diameter).

Reduced thrust losses were observed for cases with deflectors installed only on one side of the jet fan – although that may not be suitable for reversible flow operation. With one set of deflectors installed at 0.4D from the discharge silencer, a thrust reduction of about 7% was measured. With one set of deflectors installed at 0.4D from the inlet silencer, a thrust reduction of 4.5% was measured.

In the second series of measurements, two different types of deflectors – namely rectangular (as previous) and circular, were measured using the same bench thrust rig. The fan blade pitch angle was set to  $37^\circ$  for this set of measurements, and the baseline thrust was 728.1 N. Figure 4 summarises the outcome of these measurements.

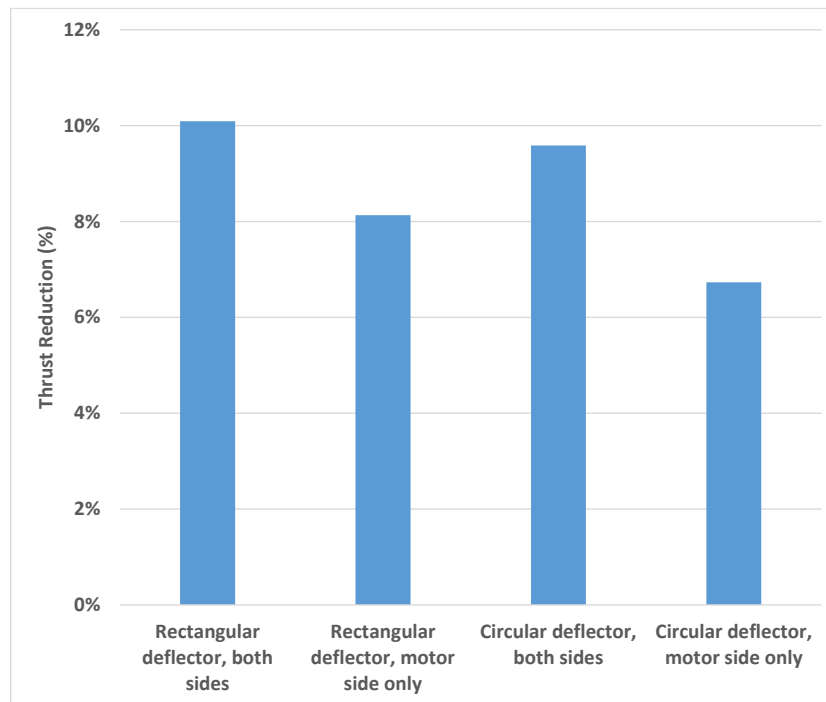

Figure 4: Thrust Reduction as a Function of Deflector Type and Installation

The results in Figure 4 indicate that the circular deflector exhibits marginally less thrust reduction when installed on both sides of the jet fan, although the difference was within the range of experimental uncertainty. The reduction in thrust may be reduced by installing a deflector only on the discharge (motor) side, but this technique may only be relevant for unidirectional jet fans.

The magnitude of thrust reductions measured in these experiments are consistent with those reported by Beyer et al (2016), who stated a thrust reduction of up to 9% due to the installation of deflector vanes on 1.6 m internal diameter jetfans at the Bosruck tunnel in Austria.

### 3. REGENERATED NOISE DUE TO DEFLECTORS

Air velocities of typically between 30 to 40 m/s are discharged from the jet fans and strike the vanes. This causes noise to be generated due to two effects: vortex shedding behind the vanes, and mechanical vibrations of the vanes.

The increase in sound power level due to the installation of deflectors was measured for the same sets of jet fan configurations measured in the previous section. The acoustic measurements were undertaken using an intensity probe on the inlet side of the jet fan, on the basis of ISO 13347-4:2004 “Industrial fans - Determination of fan sound power levels under standardized laboratory conditions - Part 4: Sound intensity method”. Measurement uncertainties were in accordance with ISO 13347-1:2004, ranging from 3 dB at 50 Hz down to 1.5 dB at 1000 Hz.

Figure 5 summarises the measurement results for the first set of measurements (undertaken with a fan blade pitch angle of  $32^\circ$ ). The baseline sound power level for this set of measurements with no deflectors installed was 108.8 dB(A). The shape of the curves in Figure 5 was somewhat unexpected, in that a reduction in regenerated noise was observed by moving the deflectors away from the end of the silencers by 0.2D, but this was followed by an increase in noise levels when the deflectors were moved a further 0.2D away from the silencers. The reason for this behaviour is unknown, but may be due to fluid-structure interaction of the airflow with the deflector vanes.

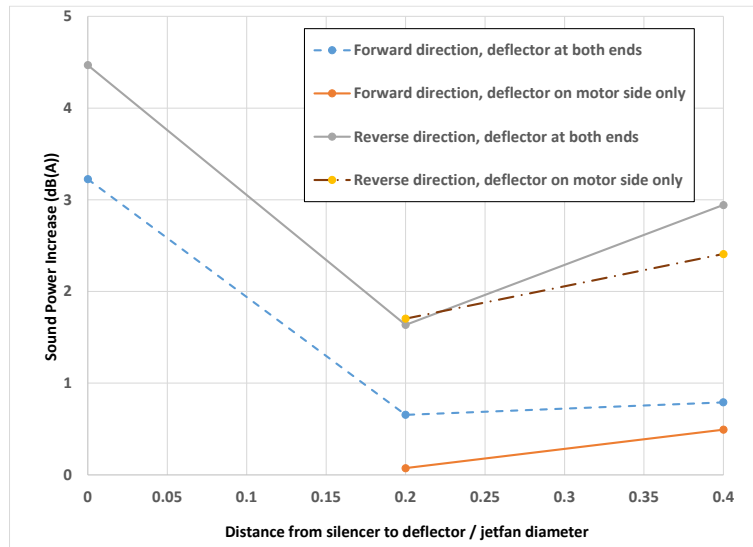

Figure 5: Sound Power Increase as a Function of Deflector Location

A second set of measurements were undertaken with a fan blade pitch angle set to  $37^\circ$ , and with the deflectors installed at 0.4D from the silencers. A baseline sound power level of 109.7 dB(A) was measured in the absence of any deflectors. Figure 6 summarises the results of the sound power level measurements for the two types of deflectors and installations (on one side of the jet fan or on both sides). The results established that the type of deflector made no significant difference to the measured sound power level. The least level of additional noise was generated with a circular deflector installed on the discharge (motor) side only.

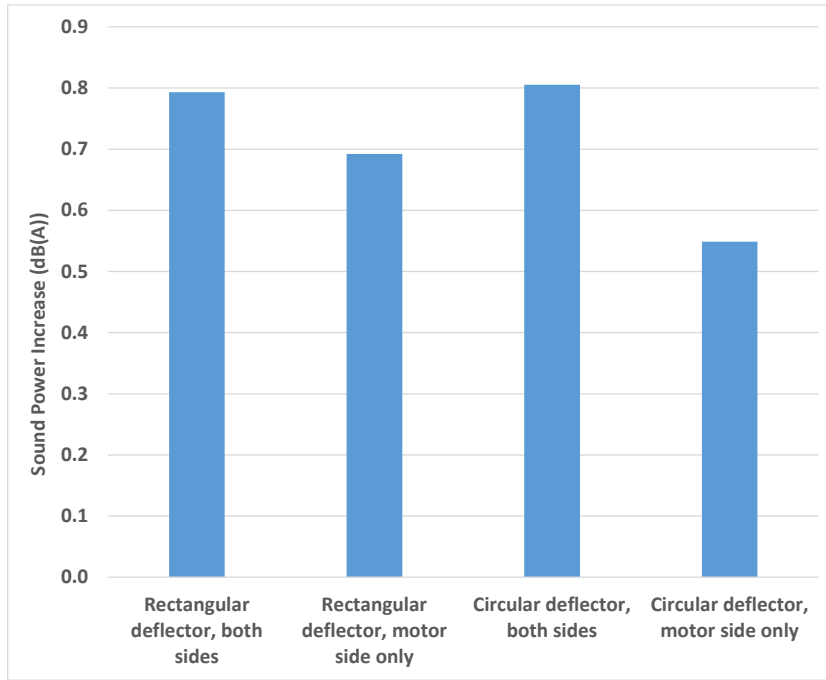

Figure 6: Sound Power Increase as a Function of Deflector Type and Installation

#### 4. POWER CONSUMPTION

Due to the additional aerodynamic resistance imposed by the deflectors, the motor input power of the jet fans will increase, compared to the case without any deflectors. Measurements of the effect of deflection vanes on the input motor power of a jet fan were undertaken for the same conditions presented in the previous section. The measurements were made in accordance with ISO 13350:2015, and have an uncertainty range of  $\pm 2\%$ . For the first set of measurements, the baseline input motor power with no deflectors installed was 18.2 kW, at a blade pitch angle of  $32^\circ$ . Figure 7 summarises the results of the measurements.

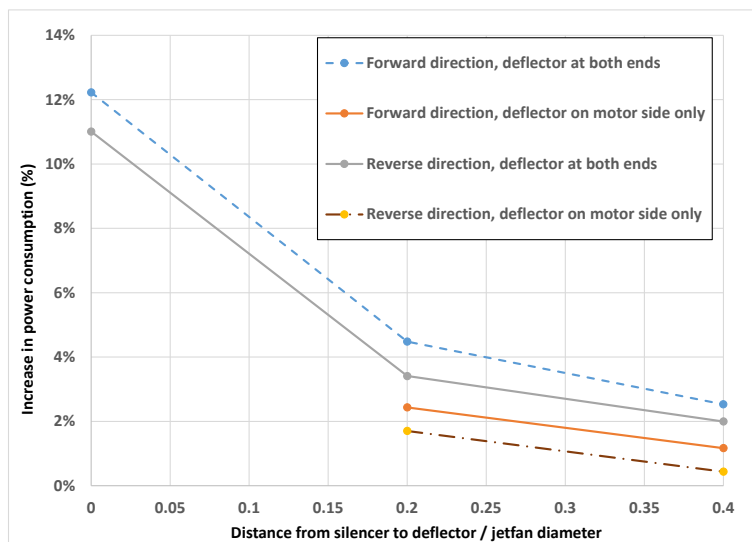

Figure 7: Increase in Motor Input Power as a Function of Deflector Location

Figure 7 confirms that the increase in motor input power reduces as the distance between the jet fan silencer and the deflector is extended. Nevertheless, a 4.5% increase in input motor power was recorded for airflow in the forward direction, with deflectors at both ends of the jet fan installed at 0.2D from the silencer.

A second set of measurements were undertaken with a fan blade pitch angle set to  $37^\circ$ , and with the deflectors installed at  $0.4D$  from the silencers. A baseline input motor power of 30.9 kW was measured in the absence of any deflectors. Figure 8 shows the results of this part of the investigation. This indicates that increases in motor input power can be ameliorated by the design of the deflectors, although only marginally.

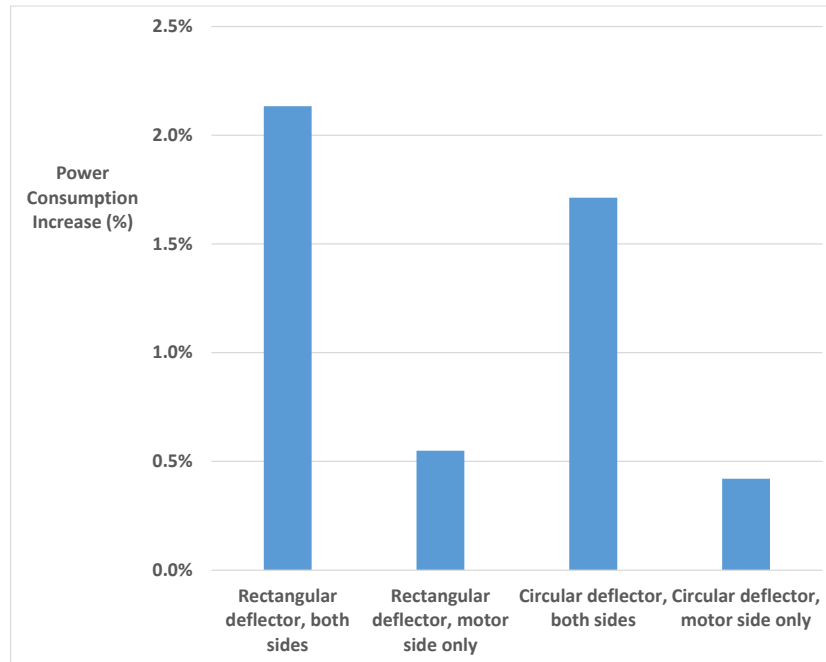

Figure 8: Increase in Motor Input Power as a Function of Deflector Type and Installation

## 5. STRUCTURAL INTEGRITY

The jet-induced excitation of the vanes causes them to vibrate at their natural frequency and multiples thereof. Depending on the natural frequency and the robustness of the fixings, the vanes may be prone to fatigue-induced failure.

The fatigue life of the deflector vanes can be assessed by the methods described in BS 7608:2014+A1:2015 “Guide to fatigue design and assessment of steel products”. This defines classes of welds, and predicts the fatigue life for each class at various stress levels using S-N curves. Welded joints between the deflector vanes and the frame are particularly vulnerable to failure through fatigue. If failures occur, they may potentially cause the vanes to fall onto moving traffic below, and this presents a safety risk. Fan manufacturers, installers, consultants and tunnel operators may all be liable for any injuries or deaths, even after the expiry of any warranty periods.

A typical  $L_{10}$  bearing life (in accordance with ISO 281:2007 “Rolling bearings - Dynamic load ratings and rating life”) for a jet fan is 20,000 operating hours, and for safety reasons the deflector should have a significantly longer fatigue life than the bearing life, e.g. 100,000 operating hours. Tunnel inspections (undertaken to the Highways England (2020) CS 452 standard, for example) should prioritise the inspection of deflector vane joints on a risk-assessed basis.

## 6. JET THROW

The flow discharged from jet fans exhibits a high degree of swirl from the rotating blades, which assists in dissipating the jet and imparting its axial momentum to the tunnel air within a short distance. Deflection vanes tend to kill the swirl and hence significantly extend the jet throw. Depending on the vane deflection angle, this extended throw can cause the jet to attach

to the tunnel floor, as shown by the 3D CFD calculations presented by Tarada and Else (2018). These calculations indicated that the aerodynamic friction between the jet and the tunnel floor can significantly reduce the jet fan installation factor, from 0.84 for a conventional jet fan to 0.60 for a jet fan with deflectors.

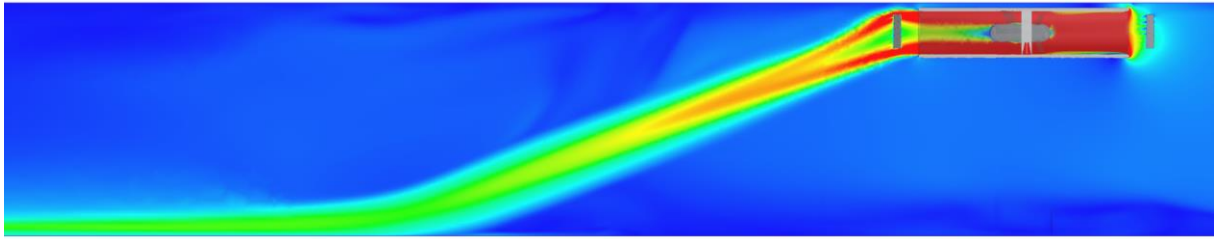

Figure 9: Velocity Contours with Deflectors (from Tarada and Else (2018))

The increase in jet throw when swirl is removed has been confirmed by Cozzi et al (2018). Figure 10 compares the time-averaged axial velocity profiles for jets with a low swirl number ( $S=0.45$ ) with those for zero swirl ( $S=0$ ).  $S$  is defined by Cozzi et al to be the ratio of axial flux of angular momentum to the axial flux of axial momentum multiplied by the nozzle radius, such:

$$S = \frac{\int_0^R r^2 \overline{UW} dr}{\left[ \int_0^R r \left( \overline{U}^2 - \frac{1}{2} \overline{W}^2 \right) dr \right] * R} \quad (\text{Equation 1})$$

where  $r$  is the local radius,  $R$  is the nozzle radius,  $U$  and  $W$  are the axial and azimuthal velocity components respectively.

At 2.5 jet diameters from the discharge plane, the peak axial velocity decays to approximately 60% of the bulk velocity with a low swirl number ( $S=0.45$ ), compared with 90% of the bulk velocity with zero swirl.

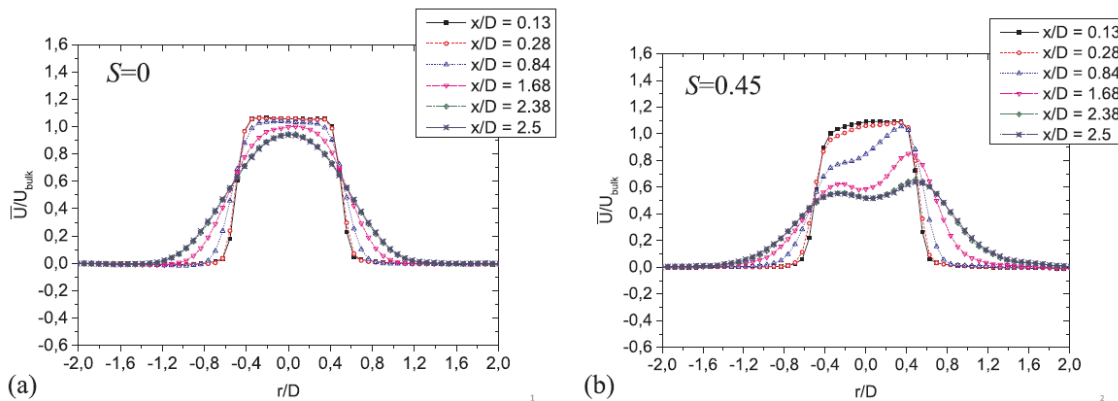

Figure 10: Effect of swirl on axial velocity profiles in an isothermal jet (Cozzi et al, 2018)

The extended jet throw with deflectors may have negative consequences on vehicles travelling within the tunnel due to buffeting forces, particularly for high-sided vehicles such as heavy goods vehicles (HGVs) and vulnerable users such as motorcyclists. Pedestrians and emergency responders walking along the tunnel may be subjected to air velocities in excess of the recommended maximum. Both NFPA 502 “Standard for Road Tunnels, Bridges, and Other Limited Access Highways” and NFPA 130 “Standard for Fixed Guideway Transit and Passenger Rail Systems” (2020 editions) specify a maximum air velocity of 11 m/s within occupied zones, with NFPA 130 expressly stating that local, rather than area-averaged, velocities should be considered.

In addition to potential buffeting forces, another drawback from the use of deflectors is that the attachment of the jet onto vehicles such as HGVs in road tunnels and trains in rail tunnels increases the shear stresses along such vehicles and reduces the jet fan installation factor. For a non-swirling jet turned by  $8^\circ$ , Betta et al (2010) showed that the inlet tunnel velocity in a traffic jam fire scenario was less than the equivalent case with no turning of the jet. However, many commissioning tests are undertaken in empty tunnels, where the effect of jet attachment onto stationary vehicles is not captured.

## 7. SHIPPING AND INSTALLATION WITHIN TUNNEL

Deflection vanes are slender bits of metal attached to an otherwise robust jet fan. In order to avoid damage during transit, it is common to separate the vanes from the jet fans during shipping. The vanes are then installed in-situ, after the jet fans have been hung onto the tunnel soffit. This is a further step that should be scheduled during the installation stage.

## 8. SUMMARY AND CONCLUSIONS

Deflectors potentially provide a significant advantage in improving the in-tunnel thrust delivered by jetfans. However, they can also produce penalties in terms of reduced jet fan bench thrust, increased noise production, higher power consumption, risk of structural failure due to fatigue and extended jet throw causing the buffeting of vehicles and pedestrians during use. The optimisation of deflector location and vane deflection angle can assist in mitigating, but not eliminating, some of these negative aspects. Modern alternatives to the use of deflectors including the MoJet have been developed, and have demonstrated superior performance (Tarada et al, 2019).

## 9. REFERENCES

- Beyer M., Sturm P.J., Saurwein M. and Bacher M. (2016), *Evaluation of Jet Fan Performance in Tunnels*, 8<sup>th</sup> International Conference ‘Tunnel Safety and Ventilation’, Graz.
- Betta, V., Cascetta, F., Musto, M. and Rotondo, G. (2010), *Fluid dynamic performances of traditional and alternative jet fans in tunnel longitudinal ventilation systems*, Tunnelling and Underground Space Technology 25, pp. 415–422.
- Cozzi, F., Coghe, A. and Sharma, R. (2018), *Analysis of local entrainment rate in the initial region of isothermal free swirling jets by Stereo PIV*, Experimental Thermal and Fluid Science 94 (2018) 281–294.
- Highways England (2020), CS 452, *Inspection and records for road tunnel systems*.
- Lotsberg, G. (1997), *Investigation of the Wall-friction, Pressure Distribution and the Effectiveness of Big Jetfans with Deflection Blades in the Fodnes Tunnel in Norway*, 9th International Symposium on Aerodynamics and Ventilation of Vehicle Tunnels, Aosta Valley, Italy.
- Tarada, F. and Else, K., *Technologies for the Improvement of Jetfan Installation Factors*, 9th International Conference ‘Tunnel Safety and Ventilation’ 2018, Graz.
- Tarada, F., Else, K., Domoney, A., Hendrick, P., Tarhach, A., Mugisha, A., Kabuya, A. and Sermeus, B., *MoJet Tunnel Ventilation – Full-Scale Testing and CFD Analysis*, 18<sup>th</sup> International Symposium on Aerodynamics, Ventilation and Fire in Tunnels, Athens, Greece, 25<sup>th</sup> – 27<sup>th</sup> September 2019.